



THE CORPORATION OF THE TOWNSHIP OF HORTON
PROTECTIVE SERVICES COMMITTEE

September 15th, 2022
5:00 p.m.

1. Call to Order
2. Declaration of Pecuniary Interest
3. Minutes from Previous Meeting
 - i. March 17th, 2022
4. Fire Chiefs Report and Update
5. Staff/Committee Members Concerns
6. New Business
7. Next Meeting Date
 - i. October 20th, 2022 – 5:00 p.m.
8. Adjournment

PG.2

PG.4

RETURN TO AGENDA

THE CORPORATION OF THE TOWNSHIP OF HORTON

Protective Services Committee MeetingMarch 17th, 2022

5:00 p.m.

There was an electronic Meeting of the Protective Services Committee on Thursday March 17th, 2022, via Zoom. Present was Chair Lane Cleroux, Deputy Mayor Glen Campbell, and Mayor David Bennett. Public Advisory Member present was Spencer Hopping. Staff present was Fire Chief Allan Cole, Deputy Fire Chief Mike Fortier, and CAO/Clerk Hope Dillabough - Recording Secretary

1. CALL TO ORDER

Chair Cleroux called the meeting to order at 5:01 p.m.

2. DECLARATION OF PECUNIARY INTEREST

There was no declaration of pecuniary interest expressed by Members of the Committee.

3. MINUTES FROM PREVIOUS MEETING

i) February 17th, 2022

Moved by Deputy Mayor Campbell

Seconded by Spencer Hopping

THAT the Protective Services Committee accept the Minutes of February 17th, 2022.

Carried

Public Advisory Member John Purdon arrived at 5:12 p.m.

4. FIRE CHIEF'S REPORT AND UPDATE

Fire Chief Allan Cole verbally presented the report. He discussed the call outs from February 16th -March 15th, 2022. Deputy Chief Mike Fortier reviewed the business plan for replacement of Truck 9837. It has been certified and passed inspection for the 2022 year. Deputy Chief Fortier discussed there is no panic for replacement at this time but would like to start the process in looking. Some of the decals, lights and various other items are recommended to be taken from the existing truck to the potential new truck. Mayor Bennett discussed the potential of looking at a mini-pumper instead of a half ton to be added to the fleet and then once received the old pumper (9624) would be declared surplus. There was discussion regarding supply chain and demand and timeline as it pertains to both proposed vehicles. There was consensus for staff is to do some research regarding the mini-pumper to be brought back to the next scheduled Protective Services Committee Meeting and table the recommendation of replacement of 9837.

Chair Cleroux mentioned it might be a great opportunity for the Fire Chief and Deputy Chief to make a fleet presentation to Council with all of the information pertaining to existing fleet and the future wants and needs.

There was discussion that until the CRA and the AMP are developed and finalized (June-July 2022) it might be more worthwhile to wait and see what comes out of both reports to further research needs of the Fire Department.

5. Proposed Mandatory Firefighter Certification Slideshow

Fire Chief Cole presented the proposed mandatory firefighter certification. There was discussion at the Committee regarding projected costs of additional training and education.

Chair Cleroux requested that the Fire Chief present the same information to Council as a whole.

6. STAFF/COMMITTEE MEMBERS CONCERNS

RETURN TO AGENDA

Mayor Bennett discussed the letter provided by Chief Cole and that Committee recommend that \$500.00 be donated to Shawn Johnston's undertaking of conflict response.

Moved by Spencer Hopping

Seconded by Deputy Mayor Campbell

THAT the Protective Services Committee recommend to Council to donate \$500.00 towards the efforts put forward from Shawn Johnston as it pertains to his response to the conflict in Ukraine.

AND THAT this is compliant with the Township's Donation Policy.

Carried

7. NEW BUSINESS

None

8. NEXT MEETING DATE

The next meeting will be held April 21st, 2022, at 5:00 p.m.

9. ADJOURNMENT

Chair Cleroux declared the meeting adjourned at 7:01 p.m.

CHAIR Lane Cleroux

CAO/CLERK Hope Dillabough



Township of Horton COUNCIL / COMMITTEE REPORT

Title: Monthly Fire Report	Date:	September 12, 2022
	Council/Committee:	Fire Committee
	Author:	J. Allan Cole – Fire Chief
	Department:	Fire

CALL OUTS/RESPONSES:

Call-Outs/Responses May 23, 2022, to September 12, 2022

- Hydro Pole on Fire (x1)
- Locked Door Rescue Request (x1)
- MVC (x11)
- Fire Alarm Activation – Single Family Home (x1)
- Bonfire Burning Complaint (x1)
- Vehicle Fire (x1)

MEETINGS:

Chief's Meeting 2022-06-08 1900 hrs. Eganville.

TRAINING/WORKSHOPS/:

- TFT Hose Nozzle Training Day – Pembroke Fire Hall
- Firefighters working on the knowledge portion of Action Training Program NFPA 1001 FF1&2
- Pump/Drafting Training/Refresher – Horton Boat Launch
- Ropes and Knots
- Downed Firefighter Search and Rescue-SCBA Air Tank replacement in hazardous atmosphere
- Revised Response Protocols (specific to Medical Assist-MVC Suppression) – new SOG's required
- Assistant to the Fire Marshal – Online Training for Company Officers

CORRESPONDENCE:

- Memorandum – Ministry of Health – Re: Horton FD – Response Plan Update & Continued Focus on Fire Call taking for MVCs (attached)
- Fire Marshal's Public Fire Safety Council/Enbridge – 2022 Safe Community Project Zero Smoke Alarm Campaign (attached)

RETURN TO AGENDA

FIRE PREVENTION/INSPECTION:

June 27, we held an Open House at the Fire Hall with a dual purpose in mind. One, to promote the HFD and highlight some of the many services we offer and two, to invite prospective recruit candidates to come and participate in a meet and greet with FD personnel. We can confirm that this initiative was successful on both counts.

July 01 HFD was on hand at the Horton Community Centre for the Canada Day Celebrations. We were promoting Fire Safety and handing out our Spring into Summer Fire Safety packages. A successful endeavor.

Reminder to keep all combustibles away from flammables. A good example is in the Furnace Room at the Twp. Office. This area should be kept clear of common combustibles and cleaning supplies at all times.

OUTSTANDING ISSUES/OLD BUSINESS:

RFQ for Horton 9837 Replacement – ¾ ton 4 x 4 truck
Working on RFQ for replacement of Unit 9624 (pumper)

Update:

We received 2 unsolicited bid quotes for both a Mini-Pump Unit and a 3/4 Ton Truck Unit fully fitted out. We have not confirmed, but these units may be in stock. If that were the case, we would be working on a detailed business plan to further investigate the purchase of a fully fitted out 3/4 Ton as opposed to soliciting bids from multiple sources to try and purchase a truck and fit it out ourselves.

Fire Department Access on Private Roads within the Municipality

There are 149 registered Roads in the Township that have 911 addresses attached to them (Info based on CACC 911 Reporting Data).

Of the 141 registered Roads, 61, or 43% are deemed to be Private Roads not maintained by the Municipality and of varying roadbed condition.

We have completed the Private Road Condition Assessment on 61 Private Roads in the Township

Please see attached Summary Sheet indicating Road Condition.

Based on our observations there are a sizeable number of 911 addresses located on private roads where we, as a Fire Department, could not provide the same level of service as would be expected of 911 addresses on Municipally Maintained Roads.

The following are some suggested options based on reviews of situations encountered with other municipalities having similar conditions.

- 1- Based on above, evaluate whether the FD has the appropriate equipment to meet the needs of the homeowners of these roads and consider alternate methods of response that may meet the minimum standards (IE: perhaps we would be well served with a Mini-

Pumper for this type of work-dependent on number of roads, # of homeowners, # of roads inaccessible by the larger trucks etc.)

- 2- Consider either a) developing a By-Law establishing minimum road standards and enforcing compliance or b) revise the current E&R By-Law to indicate that HFD will do it's best to provide an appropriate level of service but based on road condition we may not be able to.
- 3- Inform all homeowners serviced by Private Roads of the level of Emergency Response they are most likely to get based on the above.

How would you like us to proceed?

NEW BUSINESS

Community Risk Assessment update.

The final version of the CRA has been reviewed and accepted by HFD Senior Management. A Special Close Council Meeting has been scheduled for September 27 to brief Council on the findings of the report.

Mandatory Firefighter Certification Legislation.

O. Reg 343/22 Firefighter Certification has been filed under the FPPA 1997 Act as of April 14, 2022.

It will come into effect July 01, 2022.

HFD is actively reviewing training methodology to allow compliance with the new legislation within the allotted time frame.

Firefighter Staffing

August 15, 10 firefighter candidates completed a written examination, and we will be conducting our practical testing on Saturday September 17.

Once completed, identified candidates will be contacted for an interview with a section of recruits being identified for hiring.

Tender PW 2022-05 Schedule B

Tender was awarded and all work completed to the satisfaction of HFD personnel.

Vehicle Maintenance

9614 threw a driveshaft hanger bearing and was out of service for approximately 24 hours until repairs effected.

Annual Pump testing on 9614 and 9624 will take place Friday September 16

Project Zero

We were successful in our Fire Marshal's Public Fire Safety Council/Enbridge application to participate in the 2022 Project Zero Smoke Alarm Campaign and as such will be receiving 120 smoke alarms worth an estimated value of over \$7,000.00. This will be another step in our ongoing fire prevention program.

HFD Response Protocol Review and Update

We have been in discussions with the CACC in regards to some of our response protocols and as such, a few minor revisions have been done to take some of the guesswork out of when, where and how we should be dispatched to emergency situations. This has resulted in a slight increase in responses to MVCs and we are revising our response SOGs to accommodate the change.

Demo of Battery-Operated Hydraulic Spreader Unit

We are currently demoing an Amkus Battery powered hydraulic spreader unit. This tool is rapidly turning into a “must have” piece of equipment to carry on our apparatus and its use can be varied in application. Business Plan being developed to justify a purchase, should the tool be found acceptable.

Author: J. Allan Cole - Chief
signature

Other: _____
signature

Treasurer _____
signature

C.A.O. _____
signature

Memorandum

Ministry of Health

Renfrew CACC
490 Raglan Street North
Renfrew, Ontario
K7V 1P5

Memo File Number: 02650-02-1956

Reference Files: 02650-02-1951, 02650-02-1953

DATE: July 15, 2022
TO: All Staff
FROM: Operations Manager
Re: **Horton FD – Response Plan Update & Continued Focus on Fire Call Taking for MVCs**

The Horton Fire Department has updated their Response Plan to include automatic response to MVCs whenever an ambulance is dispatched.

While many of our County FDs have now gone this route, you must continue to use the new "F4 Vehicle – Accident, Collision, Fire" card for all MVC calls when you are Call Taking. Keep this open and accessible at your desk if you find it helpful.

This card was developed with the Fire Communications Committee and reflects the criteria for tiering discussed in the June 7, 2022, memo "Monthly Focus – Fire Call Reports & FD Tiering to MVCs".

A vehicle on its side or in an unstable position (eg. overturned in a ditch, hanging off a ridge, lodged in a wall / building) is an actual or potential hazard to bystanders as well as first responders and warrants tiering of the FD. There are occasions when a vehicle on its side or upside down may not present with any other typical visual hazards (leaks, fire, smoke) but hazards are inherent due to the vehicle's positioning.

Refer to the FD Response Plans in the Fire Books / SOP Links for the dispatching of fire calls.

If you have any questions or concerns, please speak with me or an ACO2-Supervisor for clarification.

Sincerely,



Ashley Ste-Marie

RETURN TO AGENDA

HORTON FIRE DEPARTMENT

<u>Response Type</u>	<u>Response</u>
<u>Fire - Structure</u>	HOR ALL + Ambulance + Police
<u>Fire - Chimney/Flue</u>	HOR ALL
<u>Fire - Vehicle</u>	HOR ALL
<u>Fire - Wildland (Grass, Bush, and Forest)</u>	HOR ALL
<u>Fire - Fire Alarm, Smoke Alarm, and CO Detector</u>	HOR ALL
<u>Fire - Trouble Alarm (problem with fire protection system)</u>	HOR ALL
<u>Fire - Hydro Lines Down and/or Arcing</u>	HOR ALL
<u>Medical Assist</u>	Yes - via Allied Agency request ONLY
<u>Hazardous Materials</u>	HOR ALL
<u>Rescue - Water and Ice</u>	HOR ALL
<u>Rescue - High Angle, Confined Space</u>	Do NOT Respond
<u>Rescue - Farm/Silo, Trench</u>	HOR ALL
<u>Ambulance Assistance - Lift Assist</u>	HOR ALL
<u>Ambulance Assistance - Locked-Door Access</u>	HOR ALL
<u>Police Assistance</u>	HOR ALL
<u>Public Assistance - non-emergency request</u>	Provide FD Contact Information - Township Office
<u>Public Assistance - emergency request (flooded basement)</u>	HOR ALL
<u>Public Utilities Assistance - non-emergency request</u>	HOR ALL
<u>Vehicle Accident - Suppression</u>	HOR ALL - whenever an ambulance is dispatched
<u>Vehicle Extrication</u>	See Below

***HORTON FIRE DEPARTMENT
ESTABLISHED 1967***

10



DEPARTMENT OVERVIEW

RETURN TO AGENDA

HORTON FIRE DEPARTMENT OVERVIEW/INFORMATION

HISTORY

Established in 1967, Horton Fire Department has been serving the Municipality of the Township of Horton for fifty-five (55) years and counting.

With the assistance of the Ontario Fire Marshal's Office, the required types and amount of equipment were established, and initial purchases were made.

A 1967 Ford Chassis was purchased from H. B. Elliott Ltd. Of Renfrew and this was fitted with a King Seagrave Pumper Body at a total purchase price of \$17,998.00 (in 1967 dollars)

The initial Firefighter Compliment consisted of Fire Chief Clarke Eady and eight Firefighters.

The first Firehall was at Clarke Eady's Garage on Burnstown Road. It was a heated garage and the Township paid Mr. Eady a sum of \$50.00 per month to store apparatus and equipment there.

Our current Firehall was completed at the present location of 2253 Johnston Road and the Department moved into the new facility in 1983.

In the early 2000's the hall addition was completed with the inclusion of a training room, additional washrooms, storage, offices and a third truck bay. This is the hall you see today.

PAST AND CURRENT SERVING FIRE CHIEFS

- Clarke Eady 1967 – 1979
- Chris Legris 1979 – 1984
- David M Bennett 1984 – 1985
- Guy Longtin 1985 – 1988
- Dave Campbell 1988 – 2001
- Randy Corbin 2001 – 2019
- J. Allan Cole 2019 - Present

RETURN TO AGENDA

THE 3 LINES OF DEFENCE

The Ontario Fire Marshal's Office identifies and promotes a Fire Protection Strategy known as the "Three Lines of Defence"

Line of Defence	Description
1. Public Education and Prevention	Educating residents of the community on means for them to fulfill their responsibilities for their own fire safety is a proven method of reducing the incidence of fire. Only by educating residents can fires be prevented and can those affected by fires respond properly to save lives, reduce injury, and reduce the impact of fires.
2. Fire Safety Standards and Enforcement	Ensuring that buildings have the required fire protection systems, safety features, including fire safety plans, and that these systems are maintained, so that the severity of fires may be minimized
3. Emergency Response	Providing well trained and equipped firefighters directed by capable officers to stop the spread of fires once they occur and to assist in protecting the safety of residents. This is the failsafe for times when fires occur despite prevention efforts.

STAFFING OVERVIEW

- Fire Chief One (1)
- Deputy Fire Chief One (1)
- Fire Captain Two (2)
- Firefighters Fourteen (14)
- Total Compliment Eighteen (18)

RETURN TO AGENDA



[RETURN TO AGENDA](#)

APPARATUS OVERVIEW

HFD has four active service apparatus.

First out Pumper is 9614

- Manufactured in 2018
- Freightliner / Metalfab
- 5000Lpm midship pump
- 4000L tank with 80L foam cell
- Three position master intake valves with priming available at each intake (right, left and rear)
- Class A foam available on two transverse 1 3/4 pre-connect and one 2 ½ pre-connect on the hose bed.

Second out pumper is 9624

- Manufactured min 1996
- GMC / Almonte Fire Trucks
- 4000 Lpm midship pump
- 3600 L tank
- Drafting available at rear (reduced capacity)
- Class A foam available only from single inline eductor (external)

Tanker is 9717

- Manufactured in 1992
- International / Almonte Fire Trucks
- 12000 L tank
- 4" portable pump
- 4" cabinet mounted pump
- Two 6000L portable tanks on board

Utility Pickup is 9837

- Manufactured in 2000
- Ford F250 4x4 Single Cab
- Two forestry pumps
- Five forestry hose bags of 500' ea.
- Various other forestry and utility items



[RETURN TO AGENDA](#)

WHO WE ARE

We are your neighbors, brothers, sisters, fathers, mothers, sons, daughters, cousins.

The list goes on.

We are anyone with a desire to serve the community.

We all live within reasonable commuting (response) distance to the Fire Hall, located at 2253 Johnston Road, typically 8km or less by road.

We bring a broad array of talents to the table, outside of our firefighting duties.

We are:

- Tradespeople – plumbers, electricians, carpenters
- Bell Telephone Repair Technicians
- Internet and Cable TV installers
- Paramedics
- Retail Workers
- Heavy Equipment Mechanics
- Truck Drivers
- Farmers
- Industrial Workers
- Sales Representatives
- Sellers of Propane and Propane Accessories (just like Hank Hill from King of the Hill)
- We work for the Federal Government
- We could be any of these and more.

We are people who share a common desire to help our community.

We meet or exceed the minimum health and fitness requirements of the job

We are a closely knit family..... acceptance by this family is hard. Once established, the bond translates to so much more than family.

We share common experiences, good times and bad.

We often see things on the fireground that most civilians would not, or even want to.

Our common bond helps us through those rough times

The good times are great, a successful fire knockdown, fire prevention activities, the camaraderie amongst the team.

We truly enjoy coming to the Fire Hall, it is our second home.

We are Horton Firefighters.

RETURN TO AGENDA

WHAT WE DO

It is our mission to continually strive to provide prevention, education, and fire/life safety protection services to the residents and visitors of the Township of Horton. Through teamwork, dedication and training, the members of the Horton Fire Department contribute professionally to the department's success.

Core Services

Changes in the Horton Fire Service are not unique as the fire protection industry is rapidly evolving provincially, nationally, and globally. Conventionally, volunteer fire departments would typically respond to fire situations but today, fire service personnel respond to a much more extensive array of incidents.

Development, population increases, technological advancements, and societal change are some examples that bring about an increase in community risks, placing higher demands onto service providers, including the Township's fire service.

On average, our department receives between 40 and 60 emergency call outs per year. Regular scheduled training takes place every Monday evening with additional special training from time-to-time. Members are also encouraged to attend additional professional skills training, in person and on-line.

Public education, fire prevention and public relation duties are typical firefighter requirements and occur throughout the year.

Examples of core services provided by the Horton Fire Department include:

- fire prevention
- public education
- structural firefighting
- automobile fires
- motor vehicle accidents
- grass, bush, forestry firefighting

RETURN TO AGENDA

- water/ice rescue shore base
- alarm response
- public assistance
- public utilities assistance
- mutual aid
- extensive training
- station duties
- public relations



HOLD YOURSELF RESPONSIBLE
FOR A HIGHER STANDARD
THAN ANYBODY ELSE EXPECTS OF YOU

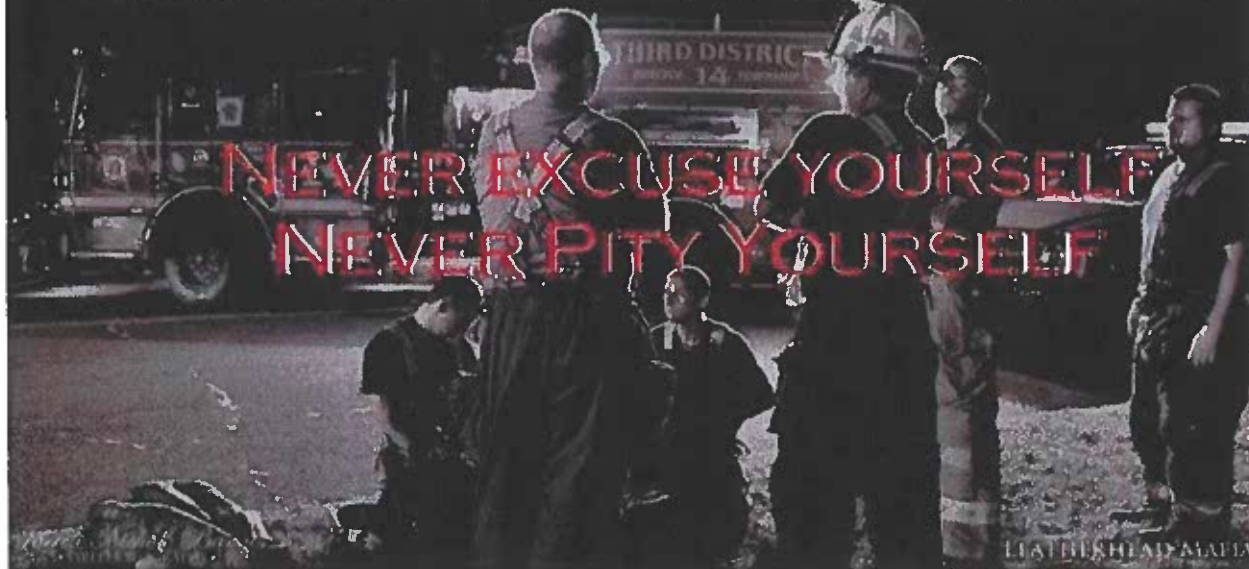

NEVER EXCUSE YOURSELF
NEVER PITY YOURSELF

RETURN TO AGENDA

VOLUNTEERING WITH HORTON FIRE DEPARTMENT **RECRUIT STAFFING PROCEDURES**

Participation as a volunteer member of the fire service brings additional benefits including increased personal satisfaction, heightened self-esteem, and a tremendous sense of accomplishment for a job well done. Your involvement will also provide your community with a valuable service that comes with the potential to touch us all.

The Horton Fire Department has implemented an evaluation process to provide all applicants with impartial opportunity.

In an effort to provide individuals who have an interest in becoming a volunteer firefighter with key information and job expectations, the individual will be required to attend a recruiting orientation session as a prerequisite to the recruitment process. After attending the orientation session, the individual will possess better awareness of the participation requirements and the nature of our business. Individuals have an opportunity to consider the commitments before making their final decision.

After attending the orientation session, the individual will be able to make formal application to become a volunteer firefighter, at which point an initial screening will be conducted to verify minimum requirements.

An applicant advancing to the next stage of the process will be considered a candidate. The evaluation process comprises of three phases.

- **Phase 1** includes the skills assessments, which are job related ability tests and are the physical component of the recruiting process. These tests will be conducted to assess the candidate's ability to perform specific job-related assignments.
- **Phase 2** is a formal interview from a panel of interviewers. Scores will be assigned based on the candidate's achievements through the process.
- **Phase 3** is the candidates list where individual scores will be ranked in ascending order. Vacant positions will be filled from the candidates list.

The next stage consists of a conditional recruit offer package. The candidate will be required to obtain and produce the following documentation: a current driver's

RETURN TO AGENDA

abstract from the Ministry of Transportation; a vulnerable sector check from the local Police service; a medical assessment from a licensed physician; and a signed fire service agreement.

An informal consultation will also be encouraged with the candidate's partner and/or family member to discuss the candidate's commitments as a firefighter.

A probationary period of one year will require the recruit to successfully acquire all necessary training and demonstrate their commitment as a member of the McNab/Braeside Fire Department.

HORTON FIREFIGHTERS' ASSOCIATION

The Horton Firefighters' Association is a member driven organization consisting of Horton Firefighters as regular members and associate members, with the Fire Chief and Deputy Fire Chief acting in an ex-officio capacity.

The association consists of a President, Treasurer, Recording Secretary and Members.

The purpose for which the Association is constituted is four-fold:

- a- to promote and further the development of fire protection and fire prevention
- b- to promote educational programs for the benefit of the membership
- c- to promote and arrange social activities for the benefit of the membership
- d- to assist with the costs of upgrading fire department equipment

The association takes the lead and/or assists with three major initiatives that take place annually within the Township. That plus a lot more.

- Township of Horton Canada Day Breakfast. Held annually each July 1st at the Horton Community Center, Horton Fire Department, with the assistance of the Association, puts up an information display, brings the trucks out and generally promotes good fire safety practices. Sparky, the Fire Safety Dog, generally makes an appearance at this fun event.
- Horton Fall Classic. This Annual Golf Tournament is held the first Saturday of October in the format of an eighteen-hole best ball tournament. The Association has teamed up with some GREAT Sponsors and last years' tourney was a real success. Substantial financial donations were made to Renfrew Hospice and the Renfrew Food bank as a result.

RETURN TO AGENDA

- Halloween Horton Haunted Fire Hall. Held October 31 each year, this event ties in as a close-out to the Ontario Fire Prevention Week activities. The Association goes all out on this one, with the creation of a Haunted Fire Hall and all the spooky sights and sounds that would be expected. This event is geared to the little ones, typically aged 10 and under. On average, we would see 100 to 200 little ghosts and goblins and their families, sending them off with a loot bag filled with goodies and some really good Fire Prevention info. Did we mention the hot dogs and drinks for the kids? Sparky never misses this event, and the kids love it.
- Every Christmas season you will see the Association quietly checking the needs of the community and making various donations to those organizations who can put the funding to best use. It's just what they do.

CONTACT INFORMATION

J. ALLAN COLE

Fire Chief / Chief Fire Inspector

Horton Fire Department

2253 Johnston Road, Renfrew, ON. K7V 3Z8

613-432-6271 x 106 office

613-281-5749 mobile

firechief@hortontownship.ca

Horton Township Municipal Office

Office Hours: Monday to Friday – 8:30 am to 4:00 pm

2253 Johnston Road

Renfrew, Ontario

K7V 3Z8

Phone: 613-432-6271

Fax: 613-432-7298

WHEN IT'S ALL SAID AND DONE, NOBODY WILL REMEMBER HOW MANY INSPECTIONS YOU COMPLETED, HOW MANY CALLS YOU ATTENDED OR HOW MANY TRAINING HOURS YOU LOGGED IN THE BOOK; THEY'LL REMEMBER THE PERSON IN THE UNIFORM.

**THE MEASURE OF WHO YOU ARE ISN'T FOUND IN METRICS. IT'S IN YOUR HEART.
BE WORTH REMEMBERING.**

**DO YOUR JOB.....
TREAT PEOPLE RIGHT
GIVE ALL OUT EFFORT
HAVE AN ALL IN ATTITUDE**



September 6, 2022

J. Allan Cole, Fire Chief
Horton Fire Department
2253 Johnston Road
Renfrew, ON K7V 3Z8

Dear Chief Cole,

We are pleased to inform you that your department has been selected to participate in this year's Safe Community Project Zero campaign.

Safe Community Project Zero provides selected fire departments in the Enbridge Gas Inc. service area with free combination smoke/carbon monoxide alarms for distribution to individuals in their communities, with a focus on those who are deemed high risk. This may include the elderly, people with disabilities or financial challenges.

Since the inception of Safe Community Project Zero in 2009, Enbridge has generously provided over 2.2 million dollars for this campaign, resulting in the distribution of over 76,000 alarms to Ontario communities by local fire departments. Many of these departments teamed up with seniors' centres, food banks, Children's Aid Societies, Meals on Wheels and other community agencies to distribute these life-saving devices where they are most needed.

As a recipient of the 2022 Safe Community Project Zero campaign, and based on the population of your community, your department will receive **120** Kidde Canada 10-year, worry-free combination smoke/CO alarms. The retail value of the alarms is approximately \$7,100.

In support of this campaign, participating fire departments are asked to:

1. Complete and return the Confirmation of Participation form to the campaign coordinator, Kathy Ash, at kathy.ash@firesafetycouncil.com or fax to 1-866-379-6667 by Thursday, September 15, 2022.
2. Collaborate with Kathy to provide information required to complete a media advisory and news release developed by Enbridge.
3. Collaborate with Kathy to arrange a media launch and photo opportunity with the fire chief and/or department representatives, to take place after November 15, 2022. Include local media, mayor/council members and representatives from Enbridge and the FMPFSC or OFM, pending local Public Health guidelines at the time.
4. Email your media advisory to local media if you are inviting them to the launch. Send them your news release and photo if they do not attend.

RETURN TO AGENDA

5. Email your photo and any local media coverage to kathy.ash@firesafetycouncil.com.
6. Share your photo on your social media sites. Tag Enbridge using @enbridgegas and use the hashtag #ENBfuelingfutures.
7. Distribute the combination alarms free-of-charge, focusing on individuals in your community who are identified by your department as high risk.
8. Complete and return the Safe Community Project Zero Summary Overview form following the distribution of your alarms.

Following the return of your Confirmation of Participation form, Kathy Ash will contact you to arrange the shipping of your alarms, assist with completing your news release and coordinate the attendance of representatives from Enbridge and the FMPFSC or OFM at your media launch. If you have any questions or concerns, please do not hesitate to contact her at kathy.ash@firesafetycouncil.com or by phone at 1-866-379-6668 ext. 105.

Sincerely,

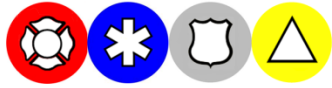

Jamie Kovacs
Executive Director
Fire Marshal's Public Fire Safety Council

**2022 Quick Response Command - Model # QRC-250 (PL220721)****Chassis:**

2022 Ford F250 4x4 Crew Cab – see attached information

Body Cap:

Leer or ARE 8 Foot Fiberglass Truck Cap

Bed Items:

Decked Drawer System

Drawer “Essential Kit”: 2x locking cases, 2x dividers, 1x tote

Cargo Glide 1,000 LBS Slide Tray

Side Steps:

Black Tubular 4” Diameter – Cab length

Wheels & Tires:

LT315/70/R17 Load E A/T Transport Canada Snow Flake Rated

ION 143 Matte Black 17”

Emergency Lighting & Siren:

Light Bar: 47 inch with integrated rear traffic advisor

Sides: 6x Strobes (3x per side side: 1x on front fender + 2x on side of cap)

Front Grill: 2x strobe lights

Tailgate: 2x strobe lights

Siren: 100W Siren with PA

Roof Cap Lighting:

18,000 Lms 1 Meter Remote Dual Head Light Tower

Six (6x) 30 Watt Flood Lights (2x per side + 2x rear)

Grill + Winch:

Westin HDX Frame Mounted Winch Mount Tray + 9,500 LBS Remote Winch + Crash Guard

Vehicle Body:

Lower portion of vehicle sides below windows to bottom to be wrapped in red 3M or Avery vinyl

“Atlantic” Reflective Graphics with rear reflective chevrons

Additional Items:

Jotto Full Length Console w/ 12v + USB outlets, cup holders, storage tray

Locking compartment in center console

Locking Clip Board Storage Compartment in console

6amp Shore Power Charger with Manual Eject

2x NMO antenna mounts on roof with cable ends coiled inside console.

Pre-wired 12v “pony panel” with 8 fuse positions - for radios & accessory items in console

Body:

Lower body below window line wrapped red. Rear tailgate will have reflective chevrons (red & lime). Municipal graphics incl (restrictions apply). A \$1500 discount is available if wrap not required

Price as equipped: \$96,900 Cdn + 13% HST (FOB Markham, ON)

Note: Payment Terms: 50% due at time of order + 50% before the vehicle leaves our facility. Licensing, Registration and Annual Inspection are in addition. As per CRA directive, we must charge Ontario 13% HST as the vehicle is being sold FOB our facility. Under no circumstance will we sell a vehicle sans HST. This includes sale to recognized indigenous communities.

Delivery across Canada is available through a third party for extra cost.

Estimated arrival date of the truck at our facility is early August. Estimated completion date is mid-late September. **Chassis specifications and added options are attached.**

RETURN TO AGENDA

FRONT LINE EMERGENCY VEHICLES

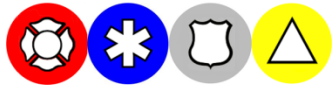

Front Line Emergency Vehicles Inc.

27

60 Bullock Drive, Unit 6, Markham, Ontario, Canada, L3P3P2

Tel: 647-886-4357 /// Fax: 416-987-4358

Website: www.FLEV.ca

2022 Quick Response Rescue

PL: QRR220705

Model: QRR-125

Chassis: 2022 Ford F550 4x4 Crew Cab (specs attached)

12.5 Foot Poly Body

Full Co-Polymer Polypropylene Construction

1" Roof Panels

3/4" Exterior & Floor Panels

1/2" Interior Panels

All joints & seams to be extrusion welded

Exterior painted to match chassis color

47" Cab Roof LED Emergency Lighting Bar (Speak with your rep about avail. colour choices)

100W Siren with Single Siren Speaker

LED Fender Mounted Emergency Lights

LED Grill Mounted Emergency Lights

Aluminum Roll Up Doors

1x Shelf in L2 & R2

2x Shelves in L3 & R3

No Shelves in L1 & R1 (Pass through compartment)

8 LED Box Flashing LED Lights (3x Driver Side, 3x Passenger Side, 2x Rear)

Rear LED DOT Turn/Stop/Reverse Lights

Full LED DOT LED Marker Lights

Chassis info attached – contact your sales rep for more info.

Quotation / Pricing subject to change – contact your sales representative before placing an order.

Payment Terms: 30% due at time of order. 45% due when chassis arrives. 25% balance due upon build completion and before vehicle leaves our production facility. We reserve the right to revoke or revise this offer at any time prior to a contract being executed. Unless otherwise stated in writing the vehicle is quoted FOB Front Line Emergency Vehicles, Markham, ON. Provincial licensing and registration are extra. Ontario's provincial 13% HST is in addition to the vehicle's sale price and must be paid regardless of the province of registration or tax exemption status.

SPECIAL FOR OUR 2022 INSTOCK & INCOMING CHASSIS UNITS ONLY

Our everyday low price: \$169,800* + HST

SPECIAL PRICING: With all items highlighted in **green**: \$219,200 + HST.

* Savings of \$10,205

* Price applies to pre-ordered chassis units only. New factory orders do not qualify for this pricing

* Changes to preselected optional equipment is at discretion of the vendor

Optional Equipment Available (continued on next page):

RETURN TO AGENDA

Optional Items:

TrailFX Full Wrap Around Grill Guard with Crash Bumper	\$2,950.00
Westin HDX Winch Mount with 10K Winch + 2 Tow Hooks:	\$3,150.00
Westin HDX Winch Mount with 12K Winch + 2 Tow Hooks:	\$3,450.00
Dual Colour LED On <u>Front</u> Lights Grill & Fenders (after credit for std lights):	\$0,360.00
High Power Box Scene Lights (2x each side + 2x rear = 6x total):	\$2,985.00
2X Additional Mid Level Emergency Lights on Rear	\$0,600.00
LED Interior Compartment Lighting (2 per door / 14 total):	\$1,980.00
High Power Off Road LED 40" Light Bar – Requires Westin Winch Mount:	\$1,370.00
High Power Off Road LED 50" Light Bar – Requires Westin Winch Mount:	\$1,580.00
Remote LED Search Light (mounted on cab roof behind Light Bar):	\$1,190.00
Rear 8 Head 60" Traffic Advisor (FLEV brand – amber only):	\$1,960.00
Rear 8 Head 52" Traffic Advisor (Feniex brand – choice of amber or red)	\$2,480.00
Ground Lighting (8 Lights):	\$1,980.00
Removable Wall – Creates compartment in L1 equal depth as L2/L3 w/ 2 shelves:	\$2,880.00
Rear or L1 or R1 Slide Tray (2,000 LBS) with 75% extension:	\$3,980.00
Rear or L1 or R1 Slide Tray (3,000 LBS) with 75% extension:	\$4,880.00
L1/R1 Transverse Slide (1,500 LBS):	\$5,220.00
3 Section Storage Unit on top of Rear or Side Slide Trays	\$3,830.00
L1 or R1 Tool Box in Drop Down Area (Each):	\$2,270.00
2x Head 1.0M LED Light Tower (18,000 Lumens):	\$3,990.00
2x Head 1.8M LED Light Tower (27,000 Lumens):	\$7,570.00
4x Head 2.5M LED Light Tower (54,000 Lumens):	\$8,980.00
4x Head 3.5M LED Light Tower (108,000 Lumens):	\$11,250.00
4x Head 3.5M LED Light Tower (216,000 Lumens):	\$14,150.00
6,000 Watt (Surge) A/C Power Inverter w/ 2x 120V outlets + 1 deep cycle battery:	\$2,980.00
12,000 Watt (Surge) A/C Power Inverter w/ 4x 120V outlets + 2 deep cycle batteries:	\$4,880.00
100 Watt Siren w/ Feniex 4200 Full Function Controller (replaces std. unit):	\$1,690.00
200 Watt Dual Tone Siren w/ Feniex 4200 Full Function Controller (replaces std unit):	\$2,690.00
Additional Shelves (priced each):	\$0,490.00
Jotto Full Console w/ 12v + USB Outlets, cup holders, clip board storage, radio mounts:	\$3,350.00
Mini Jotto Console (fits 2 radios & retains factory center folding seat/console):	\$1,750.00
NMO Radio Antenna Base installed in roof w/ cable coiled under dash (not incl. whip):	\$0,290.00
4" Oval Black Tubular Side Steps:	\$0,810.00
4" Flat Black Checker Plate Side Steps:	\$0,810.00
10" Rear Step Tailboard Bumper w/ Class V Hitch Receiver, 7 way plug + 2x Tow Hooks	\$4,490.00
Reverse Alarm	\$0,310.00
40 FT Electric Line w/ Reel (L2/R2 or L3/R3 only – req AC pwr inverter):	\$0,280.00
1x extra Electrical Outlet (110V) in any box compartment:	\$0,390.00
1x extra Electrical Outlet (110V) Inside Vehicle Cab:	\$0,660.00
4 Amp Charger/Maintainer - Manual Eject:	\$0,690.00
6 Amp Charger/Maintainer – Manual Eject:	\$0,850.00
6 Amp Charger/Maintainer with Auto Eject:	\$1,720.00
10 Amp Charger/Maintainer with Auto Eject:	\$1,890.00
15 Amp Charger/Maintainer with Auto Eject:	\$2,480.00
20 Amp Charger/Maintainer with Auto Eject:	\$2,960.00
3.1 Cubic Foot Refrigerator in L3 or R3 (req 20 Amp Charger + 12K inverter):	\$0,890.00
Wrap Upper Cab in 3M Gloss Black Vinyl	\$2,160.00
Rear Chevrons - not including roll up door (3M Prismatic Reflective):	\$1,950.00
Rear Chevrons – including rear door (3M 680CR Reflective):	\$2,750.00
Wheel Chock Storage on Curbside of Body (aft of wheel):	\$1,920.00
125 US Gallon Waterax Rancher Skid Unit w/ Hose Reel & Pump (L1/R1):	\$5,960.00
Rub Rail Reflective Stripping (Red/White alternating):	\$0,880.00
Checker Plate Rock Guard on Lower Front of Body On Each Side (incl both sides)	\$0,490.00
Checker Plate Kick Panel Rear Body – Below Door - Full Width	\$1,820.00

* Additional items such as SCBA brackets, SCBA bottle storage system, and custom storage units mounted on-top of slide trays, are available. Please ask your sales rep for assistance if you require additional items not listed herein.

RETURN TO AGENDA

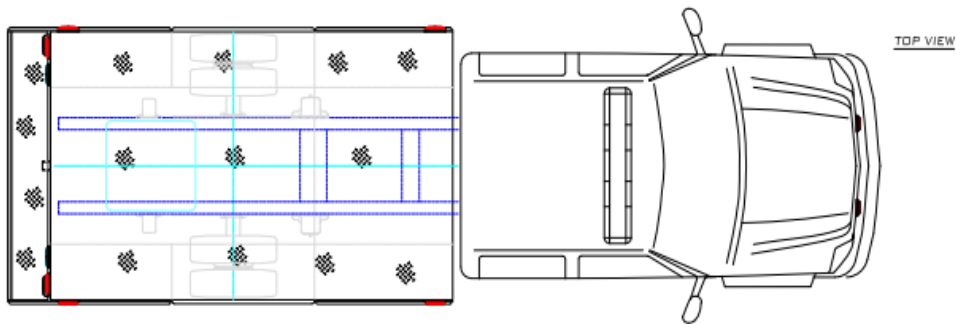

TOP VIEW

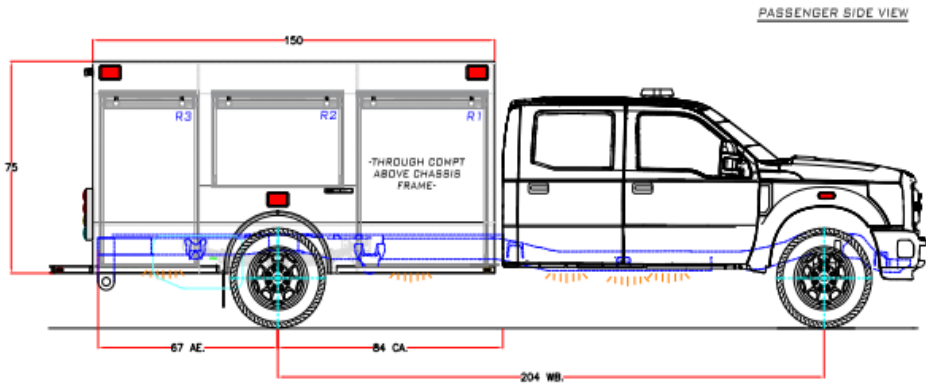

PASSENGER SIDE VIEW

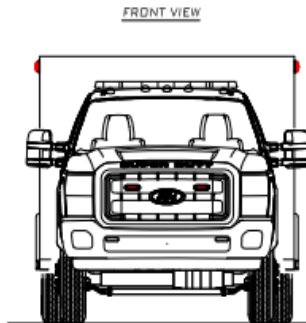

FRONT VIEW

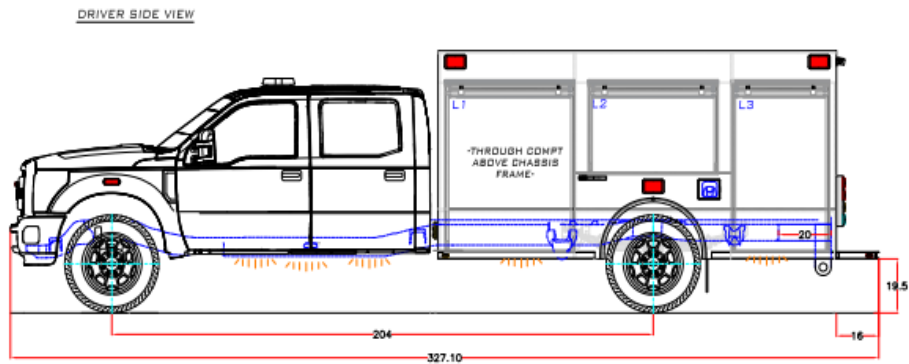

DRIVER SIDE VIEW

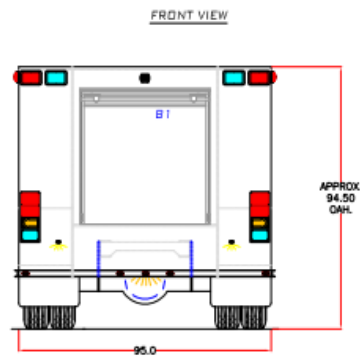

FRONT VIEW

CAB	
CAB & CHASSIS MODEL:	2022 F-550 SUPER DUTY CREW CAB 4X4
ENGINE:	7.3L 2V DEVCT NA PFI V8
HORSEPOWER:	350HP @ 3900 RPM
ENGINE TORQUE:	468 LB.FT. @ 3900 RPM
TRANSMISSION:	TOROSHIFT 10 SPEED AUTO
BVWR:	19,500 LBS.
FRONT AXLE RATING:	6,000 LBS.
REAR AXLE RATING:	13,500 LBS.

BODY MATERIAL	
POLYPROPYLENE BODY	
.188 & .125 3003 H22 ALUM. CHECKER PLATE	

COMPARTMENT DIMENSIONS					
	INTERIOR (APPROX.)			DOOR OPENING (APPROX.) W/ DOOR INSTALLED	
	W	H	D	W	H
L1/R1	50	71/56	19.5/ THRU	46	55
L2/R2	58.5	43	19.5	46	27
L3/R3	38	71	19.5	34	55
B1	54	55.5	98	46	42.5

INTERIOR CUBIC FEET: W X H X D / 1728

IMPORTANT NOTES

*SCENE LIGHTS ONLY @ REAR OF BODY

GTA Fleet Solutions Inc.
o/a Front Line Emergency Vehicles
60 Bullock Drive, Unit 6
Markham, ON, L3P3P2
(T) 647-886-4357

Sales Representative:
Vid Sansanwal
E-Mail: vid@gtafs.ca

**FRONT LINE
EMERGENCY VEHICLES**



THIS DRAWING IS A CLOSE APPROXIMATION OF YOUR FIRE APPARATUS IN ALL CASES WHERE THE DRAWING AND THE WRITTEN SPECIFICATION DIFFER, THE SPECIFICATION SHALL PREVAIL. PLEASE WORK WITH YOUR DEALER TO ASSURE THAT THE WRITTEN SPECIFICATION REPRESENTS WHAT YOU WANT IN YOUR FINISHED PRODUCT

APPROVED BY CUSTOMER: _____

DATE: _____

SALES DRAWING MAY NOT REPRESENT CUSTOMER SPECIFICATION/ RFP AND/ OR TENDER IN ITS ENTIRETY

ALL DIMENSIONS ARE IN INCHES

ALL DIMENSIONS ARE SUBJECT TO CHANGE DUE TO MANUFACTURING PROCESSES

UNLESS OTHERWISE NOTED:

TOLERANCES ARE:



THIS DRAWING IS THE CONFIDENTIAL PROPERTY OF DEPENDABLE EMERGENCY VEHICLES

DRAWN BY: PC

APPROVED BY:

PAGE:

SCALE:

INT. REV.	DESCRIPTION	DATE

CUSTOMER: STOCK POLY MINI RESCUE

DESCRIPTION: POLY WALK AROUND RESCUE

SPEC. #:

DATE: 09/14/2021 DWG. #: 57891